

4

3

2

1

THIS DRAWING IS UNPUBLISHED. RELEASED FOR PUBLICATION  
 © COPYRIGHT - By - ALL RIGHTS RESERVED.

| LOC | DIST | REVISIONS |     |                           |         |     |      |
|-----|------|-----------|-----|---------------------------|---------|-----|------|
| AF  | 50   | P         | LTR | DESCRIPTION               | DATE    | DWN | APVD |
|     |      | E         |     | REVISED PER ECR-13-001204 | 28MAY13 | KH  | PD   |

1 SUPPLIED IN LOOSE PIECE.

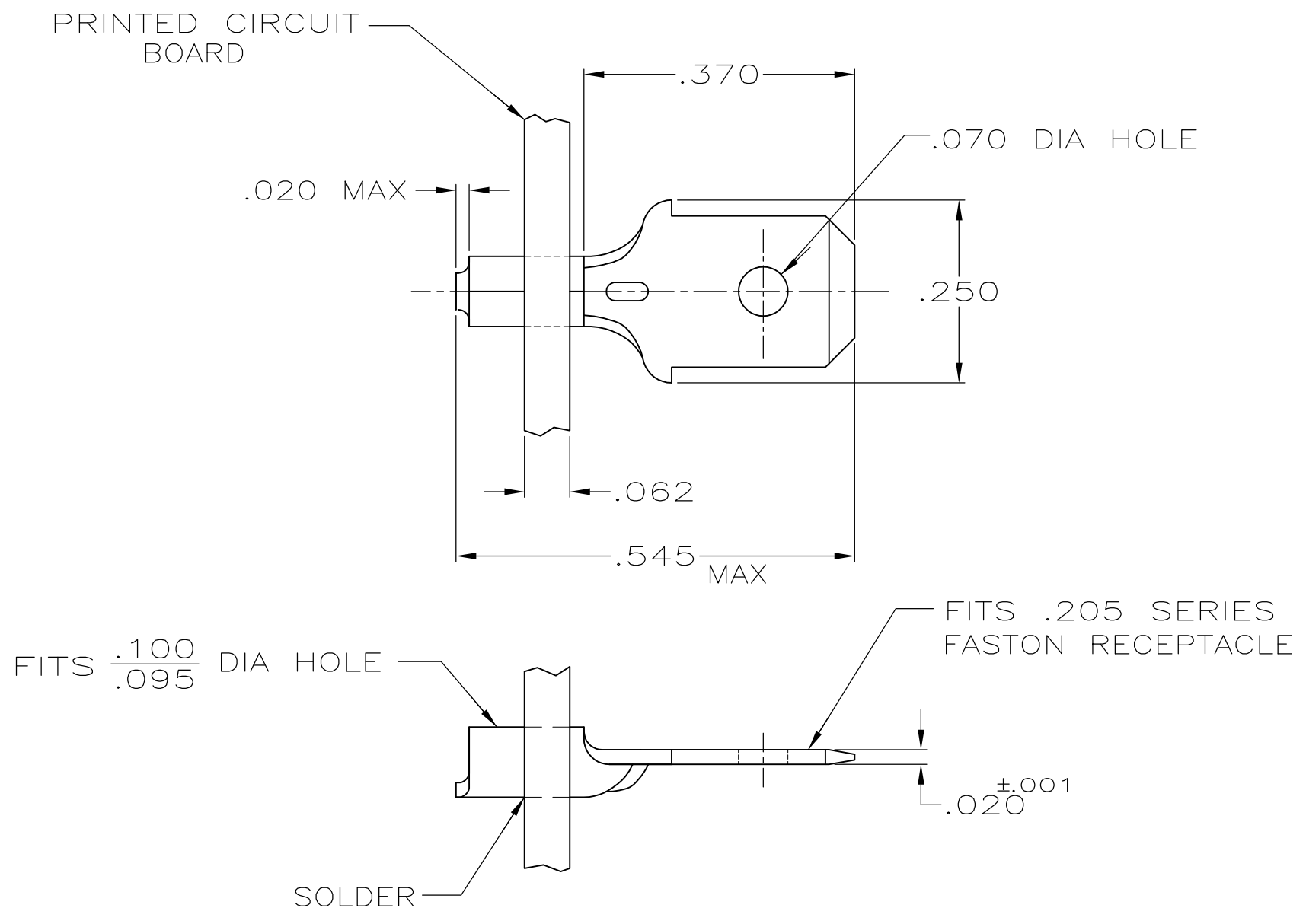

OBSOLETE

|                 |                    |
|-----------------|--------------------|
| TIN OVER COPPER | 60284-2            |
| -               | <del>60284-1</del> |
| FINISH          | PART NO            |

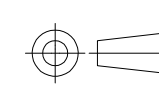
|  |       |              |           |               |   |                          |         |
|--|-------|--------------|-----------|---------------|---|--------------------------|---------|
| THIS DRAWING IS A CONTROLLED DOCUMENT.   |       | DWN          | JR RUTH   | 20SEP90       |  TE Connectivity |                          |         |
| DIMENSIONS: INCHES   |       | CHK          | P FORTNEY | 20SEP90       |   |                          |         |
|                                     |       | APVD         | C MEYERS  | 20SEP90       |   |                          |         |
| TOLERANCES UNLESS OTHERWISE SPECIFIED:<br>0 PLC ± -<br>1 PLC ± -<br>2 PLC ± -<br>3 PLC ± .015<br>4 PLC ± -<br>ANGLES ± - |       | PRODUCT SPEC | -         |               |   |                          |         |
| MATERIAL   | BRASS | FINISH       | SEE TABLE |               | NAME  | TAB, FASTON™ .205 SERIES |         |
| CUSTOMER DRAWING   |       | WEIGHT       | -         |               | SIZE  | A3                       |         |
|  |       |              |           | CAGE CODE     | 00779   | DRAWING NO               | C-60284 |
|  |       |              |           | RESTRICTED TO | -   |                          |         |
|  |       |              |           | SCALE         | 5:1   | SHEET                    | 1 OF 1  |
|  |       |              |           | REV           | E   |                          |         |